

ISSF WORKSHOP ON DECK BYCATCH RELEASE DEVICES (BRDS) FOR VULNERABLE SPECIES IN TROPICAL TUNA PURSE SEINERS

Busturia, Spain, 20-21 April 2023



© ISSF (2012)

Photo: David Itano

Murua, J., Ferarios, J.M., Moreno, G., Grande, M., Murua, H. / Oct. 2023

Suggested Citation:

Murua, J., Ferarios, J.M., Moreno, G., Grande, M., Murua, H. (2023). ISSF Workshop on Deck Bycatch Reduction Devices (BRDs) for Vulnerable Species in Tropical Tuna Purse Seiners. ISSF Technical Report 2023-11A, International Seafood Sustainability Foundation, Pittsburgh, PA, USA

Topic Categories: Bycatch mitigation, best handling and release practices, tuna purse seiners, elasmobranchs, bycatch reduction devices, fishers

Abstract

This is the report of the workshop sponsored by ISSF on deck bycatch release devices (BRDs) for vulnerable species in tropical tuna purse seiners that was held in Busturia, Spain, on 20-21 April 2023. This report summarizes the main points made during the workshop sessions and the conclusions reached.

Author Information

J. Murua, J.M. Ferarios and M. Grande | **Fundación Azti, Spain**

G. Moreno and H. Murua | **International Seafood Sustainability Foundation**
Pittsburgh, PA, 15201 USA

October 2023

The research reported in the present Technical Report was funded by the International Seafood Sustainability Foundation (ISSF) and conducted independently by the author(s). The report and its results, professional opinions, and conclusions are solely the work of the author(s). There are no contractual obligations between ISSF and the author(s) that might be used to influence the report's results, professional opinions, and conclusions.

The International Seafood Sustainability Foundation (ISSF) — a global coalition of seafood companies, fisheries experts, scientific and environmental organizations, and the vessel community — promotes science-based initiatives for long-term tuna conservation, FAD management, bycatch mitigation, marine ecosystem health, capacity management, and illegal fishing prevention. Helping global tuna fisheries meet and maintain sustainability criteria to achieve the Marine Stewardship Council certification standard is ISSF's ultimate objective. To learn more, visit issf-foundation.org, and follow ISSF on [Facebook](#), [Twitter](#), [Instagram](#), [YouTube](#), and [LinkedIn](#).

To learn more, visit issf-foundation.org.

Table of Contents

EXECUTIVE SUMMARY	4
1. INTRODUCTION.....	5
1.1 RESEARCH TO REDUCE BYCATCH	5
1.2. BYCATCH RELEASE DEVICES	5
2. WORKSHOP OBJECTIVES	8
3. WORKSHOP RESULTS	9
3.1 MINOR BRDs	9
3.1.1 MINOR BRD IMPROVEMENTS	9
3.1.2. NEW MINOR BRDs.....	14
3.2. MAJOR BRDs: HOPPERS WITH RAMPS	15
3.3. BYCATCH MITIGATION BEFORE SETTING AND SACKING	25
3.4. TUNA PURSE SEINERS OF THE FUTURE.....	28
3.5. ACTIONS TO PROMOTE BRD IMPLEMENTATION	31
4. FINAL CONCLUSIONS and RECOMMENDATIONS.....	34
ACKNOWLEDGEMENTS.....	36
REFERENCES	37
ANNEX I – LIST OF PARTICIPANTS.....	38
ANNEX II – AGENDA.....	40

EXECUTIVE SUMMARY

A participatory workshop was conducted, bringing together fishers, fleet managers, gear technologists, and scientists from various oceans to discuss the current state of bycatch release devices (BRDs) and improve handling and release practices for endangered, threatened, and protected (ETP) species such as sharks and mobulid rays in tropical tuna purse seine fisheries.

During the workshop, fishers expressed concerns about releasing large and dangerous species from the deck, including crew safety and operational time delays. Participants shared their experiences using different BRDs, such as hoppers with ramps, mobulid ray sorting grids, and shark velcros. This exchange allowed fishers who used only basic manual release protocols to learn firsthand how other fishers efficiently employ a range of tools to assist in quick bycatch releases without disrupting fishing operations and catches. While some vessels may face space limitations in employing larger BRDs, it was recognized that the size and shape of most release equipment can be tailored to fit different deck configurations.

The participants agreed on the need to review the bycatch handling and release best practice guidelines, which have not been updated in the last decade, to include well-tested new BRDs discussed in the workshop. Fishers expressed their concern about not being involved in the planning and development of sustainability actions to mitigate bycatch and they suggested the establishment of permanent scientist-fisher technical committees at regional and international levels to monitor and provide advice on bycatch mitigation and other impact reduction activities.

1. INTRODUCTION

1.1 RESEARCH TO REDUCE BYCATCH

Bycatch, referring to unintentionally caught non-target species, is considered one of the most significant and wasteful outcomes of fisheries (Davies et al., 2009; Gilman et al., 2020). Fishers are particularly interested in mitigating bycatch as it can have adverse consequences for them, including risks to crew safety during handling, limited well space, and potential fines or penalties for captains. Over the years, fishers have played a crucial role in inventing or improving effective selective gear modifications and bycatch release devices (BRDs). Examples include the Medina panel, tori lines, selective Nordmore grid, and "Georgian Jumper" Turtle Excluder Devices (TEDs) (Jenkins, 2010). Fishers' extensive experience at sea working with fishing gears and diverse species groups has allowed them to develop some of the best bycatch reduction equipment. Scientists, on the other hand, contribute complementary skills such as knowledge of the biology and behavior of target and bycatch species and the ability to conduct analytical studies to evaluate the effectiveness of selective devices (e.g., using satellite tagging technology to measure accurate post-release survival rates).

For tropical tuna purse seiners, studies have shown varying rates of post-release survival for different bycatch species. Some species, such as turtles or whale sharks, have high survival rates (Hall and Roman, 2013; Escalle et al., 2016), while others, like mobulid rays and pelagic sharks, have low survival rates (Poisson et al., 2014; Hutchinson et al., 2015). For instance, research on silky sharks caught in tuna purse seine fleets revealed post-release mortality rates of 85% and 81% in different oceans (Poisson et al., 2014; Hutchinson et al., 2015). Every fishery faces incidental catches, each with its own challenges. In tuna purse seine FAD fisheries, elasmobranchs are the primary ETP bycatch group requiring the development of effective bycatch mitigation measures to improve their post-release survival. Prior research has primarily focused on avoiding bycatch (e.g., by not encircling certain species, such as large mobulid rays), releasing sharks before brailing, and increasing survival once captured. However, safer and faster on-deck release practices are needed.

1.2. BYCATCH RELEASE DEVICES

Sometimes, it becomes challenging for the crew to manually lift adult mobulid rays due to their large size, weight, and unique morphology. These animals can reach disc widths of over 5 meters and weigh over a ton. Moreover, the release operations take place on a non-static surface, the vessel's deck, surrounded by various potentially dangerous mechanical elements such as pulling winch cables, rolling nets and chains, and a heavy brail crossing the deck. All of this is happening while the crew tries to load the catch quickly into the wells to prevent tuna histamine build-up, which can render the catches unsellable and pose health risks. As a result, the actual release actions become more complicated, and fishers are less motivated to invest time and risk their safety. The lack of tools and protocols that enable fishers to manipulate and release these large or dangerous individuals in a safer and faster way, while ensuring minimal stress to the animals, has hindered progress towards better on-deck bycatch release practices.

Since 2019, AZTI's tuna and fishing technology research areas have been collaborating with the Spanish tuna purse seine fleet (OPAGAC, ANABAC) operating in the Atlantic, Indian, and Pacific oceans, along with other key fleets (e.g., USA, Ecuador, etc.), to develop and test new Bycatch Release Devices (BRDs). These projects have received support from various public (e.g., EU Next Generation Funds, Basque Government) and private sources (e.g., ISSF) (Murua et al., 2021a). The collaborative efforts have led to the creation of several innovative BRD prototype tools, including:

- i) "Shark velcros" and "shark ropes" to replace abrasive loops used to lift large sharks
- ii) "Manta sorting grid" for swift and hands-free lifting of mobulid rays from the deck
- iii) "Shark handlers" to substitute hooks and gaffs when handling sharks

- iv) "Bycatch release ramps" have been constructed, connecting from the brail's edge or the hopper tray to the water (**Figure 1**)

These BRDs, referred to as "minor BRDs," are cost-effective to construct (e.g., shark velcros < \$100/unit, sorting grids < \$2,000, ramps < \$5,000), and their size can be adjusted to fit different vessel configurations, including smaller deck vessels.

Table 1 - Types of BRDs in tuna purse seiners employed to release vulnerable bycatch species during the brailing operation. (1) Minor BRDs; (2) Major BRDs.

BRDs	Bycatch Group	Function	Replaces
Velcros (1)	Sharks	Lift large sharks out of the brail without injury	Rope nooses
Handlers (1)	Sharks	Handle large sharks safely	Hooks, rope nooses
Ramps (1)	Sharks, turtles	Rapid and safe release	Manual lifting, ropes
Sorting grids (1)	Mobula rays	Rapid and safe release of large and heavy individuals	Hooks, canvas/net, manual lifting
Double conveyor belt and gutters (1)	Sharks	Release of sharks accidentally reaching the lower deck	Manual lifting through staircase to upper deck
Hoppers (2)	All bycatch groups	Fast release from upper deck, minimizing the manual handling and preventing accidental fall to lower deck	Manual release from the brail or lower deck



Figure 1 - Shark being safely released from the brail towards the water using a release ramp.

Another challenge encountered in purse seiners is when small sharks and other non-target species go unnoticed in the brail, ending up at the bottom and accidentally falling into the lower deck. Releasing them becomes delayed and more difficult, as they need to be carried up a narrow set of stairs to the working deck for access to the water (Maufroy et al., 2020). Some vessels have implemented **v**) opening doors or gutters in the hull of the lower deck to facilitate the release of bycatch from this area and increase survival rates (Onandia et al., 2021). Another AZTI project focuses on **vi**) hoppers ("chutes" in Spanish), which have been traditionally used in purse seiners since the 1970s, primarily for discarding unwanted small fish. However, with the prohibition of tuna discarding, these hoppers are now being repurposed for the release of bycatch species. Recent studies have shown that when designed properly (e.g., with regulated closure doors to allow time for species release if necessary), these on-deck "sorting trays" can significantly prevent sharks and other bycatch species from falling into the lower deck (Murua et al., 2021b). When combined with a release ramp, these hoppers prove to be even more effective for rapid bycatch handling and release purposes. Overall, these new or redesigned BRDs offer some of the most promising and practical solutions to increase the survival of accidentally captured vulnerable species by purse seiners.

2. WORKSHOP OBJECTIVES

The objective of this workshop was to provide a platform for fishers, scientists, and other stakeholders to exchange information and experiences related to the use of BRDs (Bycatch Reduction Devices). It aimed to facilitate a "cross-pollination" effect that promotes the voluntary adoption of marine conservation technology tools across different fleets and oceans. The workshop encouraged active participation and experience sharing through a series of exercises, where fishers with and without BRDs collaborated with scientists and technologists in mixed groups. Additionally, open discussions were held to explore ways of integrating BRDs and other mitigatory options into their daily fishing routines (refer to the agenda in [Annex II](#)).

The workshop had specific objectives from the outset:

- i) Characterizing the types of BRDs employed in the Indian, Atlantic, and Pacific Oceans, with a primary focus on hoppers with ramps
- ii) Identifying the requirements and pros and cons of BRD use based on the experiences of skippers
- iii) Redesigning tuna purse seine BRDs to optimize the release of sharks and mobulid rays
- iv) Exploring methods of constructing and integrating BRDs into newly built purse seiners
- v) Providing a comprehensive report summarizing key BRD conclusions that can serve as a guideline for tuna purse seine fleets and other organizations worldwide

Ultimately, the workshop aimed to transcend the specific theme of BRDs and foster a closer collaboration between tuna purse seine fishers and scientists. The goal was to find meaningful ways to reduce fisheries impacts and create a more sustainable fishing industry.

3. WORKSHOP RESULTS

3.1 MINOR BRDs

The first part of the workshop involved presenting the specifications and mode of use of several "minor" release BRDs through a PowerPoint presentation, which included photos and videos showcasing different designs (**Figure 2**). It was concluded that these tools can be implemented on practically any type of purse seine vessel by adapting them to specific requirements.



Figure 2 - Presentation of various BRDs used in fleets worldwide.

Following the presentation, participants were encouraged to suggest improvements to the current BRD prototypes and brainstorm additional tools that could aid in the release of bycatch. The following are some of the improvements proposed by the groups.

3.1.1 MINOR BRD IMPROVEMENTS

Shark Velcros

The Velcros should be capable of wrapping around the tails of even the largest sharks and may need to be increased in size. Some participants suggested that the Velcros could be made larger to resemble "coats" that can wrap around a significant portion of the body, not just the tail peduncle but also part of the torso. The technologists developing this device explained that they have constructed Velcros in three different sizes (M, L, and XL) to accommodate larger sharks, but even the largest XL Velcro only fastens around the peduncle (**Figure 3**). If larger Velcro devices are developed, it should be considered that they may be more challenging and time-consuming to apply to the shark compared to smaller versions.

In some RFMOs, such as the IATTC, regulations exist that prohibit lifting sharks by the tail, primarily to prevent practices such as using rope loops or "estrobos." In those regions, the use of shark Velcros is still prohibited, and an observer may

record the release of a shark lifted with Velcro as an infraction. Scientists need to provide evidence that Velcros (and other BRDs) do not harm released animals. This can be achieved by using survivorship satellite tags, for example, to ensure that managers and commissions approve their use in regulatory measures. Scientists noted that only two sharks released with Velcros have been satellite-tagged so far, and both have survived in the long term. However, more tagging experiments are required to increase the sample size.



Figure 3 - Shark Velcros of different sizes (Left) and a satellite-tagged silky shark released with a shark Velcro (Right).

Fishers have requested that Velcros be quickly and easily applied to the shark's tail for the release maneuver. While the current shark Velcros can be applied relatively fast (i.e., under 20 seconds), AZTI scientists mentioned that they are working on new release Velcro prototypes similar to those used in aquatic sports, such as surf leashes. These prototypes are cushioned to prevent skin injuries to sharks and can be applied even faster. Breakage tension tests will be conducted to ensure that the new Velcros can safely withstand the lifting weight of large sharks.

Shark Handlers

A shark handling tool was showcased during the workshop to the participants. Initially designed for safely moving hammerhead sharks, this equipment serves as a substitute for pulling ropes around the head (Figure 4). Fishers suggested that the curved parts of the handler that come into contact with sharks should be padded to minimize harm during handling. Scientists mentioned that some of the handler tool prototypes have been covered with cushioned materials on their extremities and have been given to several fishers to test and provide feedback (Figure 5).



Figure 4 - Poor release practice of a hammerhead shark being pulled using a rope noose.



Figure 5 - Different prototypes of padded shark handlers.

Manta Sorting Grids

The current manta sorting grids employed are approximately 2 m x 2 m in size, which is the same size or slightly bigger than the unloading hatch found on most vessels. However, some larger mobulids have a wingspan of 4-6 m. Fishers have suggested using larger framed grids for these extra-large specimens. Scientists and fishers who have tested the sorting grids have noted that a 2 m diameter is currently sufficient. Even with the largest mobulids, the central part of their body remains directly over the frame structure. The frame and grid provide support to the animal's vital organs, even if the wings hang out on the sides of the frame. The current frame dimensions also allow the sorting grids to fit inside hoppers (see **Figure 6**).



Figure 6 – Mobulid sorting grid fitting inside the tray of a hopper.

The frame of the sorting grid structures should have handles for fishers to hold it during use. The sorting grid is not permanently positioned on the unloading hatch or the hopper; it is only utilized during the few instances a year when large mobulids are caught. The rest of the time, the sorting grid is usually stored elsewhere and needs to be carried and positioned by hand on the hatch by the deck crew when a mobulid is caught in the brail. Since AZTI's initial sorting grid design in 2019, several new prototypes have been developed. The most notable improvements in comparison to older versions include lighter weight for easier handling (approximately 25 kg), a foldable design for better storage (with a hinge system), and adaptability in shape (some are square while others are circular to fit the unloading hatch groove) (see **Figures 7 and 8**). In small vessels that lack cranes on deck, having several handles or holding points on the sorting grid

(for example, to accommodate 4-6 crew members for lifting) may enable manual lifting of mobulids, depending on their size or weight.



Figure 7 - Mobulid rays released on deck employing a round sorting grid (left) and a square sorting grid (right).



Figure 8 - Round lightweight mobulid sorting grid with hinges for folding, in its folded (left) and extended (right) formats.

Release Ramps

Vessels with limited deck space may face challenges in storing and using release ramps. However, new practical versions of ramps with foldable parts and telescopic sections have made it easier to store ramps in small spaces (see **Figure 9**). Additionally, technologists have pointed out that the shape and size of ramps can be customized to fit the deck size, with longer ramps for larger decks and shorter ramps for smaller decks. To facilitate the work of the crew when putting on and removing the ramp before and after the brailing operation, lightweight materials such as aluminium are being used for ramp construction. Other materials, like strong yet light plastic composites, could be explored in the future.



Figure 9 - Foldable bycatch release ramp (left) and ramp folded for storage (right).

Some fishers have proposed adding a spring mechanism or elevating system to the ramps to ensure they have enough slope for sharks to move down towards the water without needing to be pushed. Naval engineers at the workshop believed this improvement could be relatively easily implemented. Keeping the ramp wet, such as by connecting a water hose, also helps make it more slippery. Additionally, a skipper suggested the use of small conveyor belts on the upper deck to move the bycatch from the brail or hopper towards the water. Fishers are already familiar with conveyor belt systems, as they are commonly found on the lower deck of most modern super-seiners.

Lower Deck Release Gutters

Some vessels have lower deck openings or gutters for releasing bycatch that accidentally goes down towards the wells. Although these gutters are categorized as "minor BRD," opening one may require significant modifications in some cases, especially when fitting a double conveyor belt, which can entail considerable costs and be considered a "major BRD." It is important to note that the gutter door must have a double safety system to prevent water entry and must pass a safety audit for validation. In a few specialized purse seine vessels, the bycatch is extracted from the main conveyor belt and deposited onto a secondary conveyor belt that connects to the gutter (see **Figure 10**). Usually, these vessels had the double belt system incorporated during construction, as retrofitting would be a considerable modification. Therefore, for older vessels with newly opened gutters, most do not have a secondary conveyor belt, and fishers still need to manually transport sharks and other bycatch to the gutter opening. In some cases, the distance between the conveyor belt and gutter can be 10 meters or more, making it dangerous to manually carry large sharks. Fishers have suggested the addition of an aid, such as a chute or ramp, to safely move bycatch from the conveyor belt to the gutter. This connecting element should not be fixed but instead should be mobile, as fishers often need to move along the length of the conveyor belt and do not want to encounter structural obstacles. Additionally, considering the varying wells being filled (closer to the stern or the bow), a flexible chute system that can be adjusted in length would be helpful. The use of wheeled support frames for the connecting chutes/ramps, as seen in some Japanese vessels without conveyor belts (see **Figure 11**), may serve as an adaptable idea for bycatch transport from the main conveyor belt to the gutter.



Figure 10 - Lower deck double conveyor belt for bycatch release (left) and closed gutter on the side of the lower deck wall (right).



Figure 11 - Fishers manually moving sharks from the conveyor belt in the lower deck to the gutter (left) and mobile system with chute sections and wheeled supporting frames (right).

3.1.2. NEW MINOR BRDs

Manipulation suction discs

Ramps have proven effective in reducing direct contact between fishers and sharks, but there is still a crucial moment when fishers need to extract the shark from the brail and/or hopper and place it on the ramp. While tools like shark handlers or velcros can be helpful, there are instances where extracting bycatch from the brail or hopper becomes challenging due to limited visibility or accessibility to the shark's body. This situation occurs frequently, especially when bycatch individuals are entangled amidst a mass of tunas in the brail.

Fortunately, new technological advances are emerging, such as suction discs or cups with a strong grip and delicate adhesion. These suction discs are designed to have a powerful grip that can lift heavy weights, while also allowing for precise manipulation of delicate body organs during operations. They are effective on various surface conditions, whether smooth or rough, dry or wet (see **Figure 12**). These suction discs are inspired by clingfish suckers, which can firmly adhere to underwater rocks yet easily release objects when needed (Sandoval et al., 2019).

To enhance the safety of bycatch releases, handles with suction discs resembling suction cups, similar to those used for moving windows, could be developed. Alternatively, blankets equipped with these suction cups could be used. By employing these tools, fishers can move sharks safely and efficiently onto the ramps. This approach offers a physical safety barrier between the fisher's hand and the animal, eliminating the need for crew members to wrap their hands and

arms around the shark's body. Moreover, the gentle suction cups are designed to minimize body trauma caused by improper handling practices, such as grasping sharks by the gills.

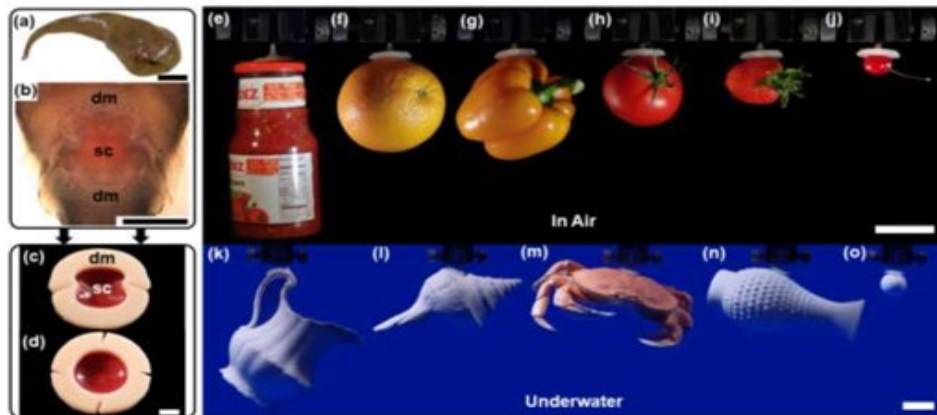

Figure 12 - Suction discs based on the clingfish's ability to hold onto highly variable surfaces in the air and underwater (adapted from Sandoval et al., 2019).

Controlled traction aids

When a medium-to large-sized shark is deeply embedded within a braill's mass of tuna, extracting it becomes challenging. In such cases, a common but poor practice involves placing a rope around the tail and having one or two deck crew members pull it out. This yanking or jerking action, involving abrupt pulling and stopping, can be detrimental to the animal's well-being.

To address this issue, implementing controlled traction aids near the unloading hatch area could significantly improve the extraction process. For example, an electric pole or windlass could be installed on the sidewall of the winch or the starboard wall. This setup would allow for the shark or other large bycatches, such as marlins, to be extracted in a steadier and less abrupt manner. Additionally, it is crucial to replace the rope used for pulling with a non-abrasive and padded element, such as shark Velcro, or to utilize tools like the aforementioned suction discs.

Shark wheel carts

During the net-hauling process, sharks often become entangled in the purse seine net before the sacking operation begins. Untangling these sharks poses significant difficulties and risks. In the past, poor practices involved pulling them with a rope from the tail, which is both unsafe and harmful to the animals. To address this challenge, a suggested solution is the implementation of lightweight yet sturdy "wheel carts" that can be operated by a single crew member. These carts would facilitate the safe transportation of larger sharks across the deck, minimizing stress and potential harm to the animals.

3.2. MAJOR BRDs: HOPPERS WITH RAMPS

During the second exercise of the workshop, several skippers, including those from companies such as Garavilla Bolton Group (Ecuador), Cape Fisheries (USA), Via Ocean Bolton Group (France), and Caroline Fisheries Corporation

(Federated States of Micronesia), presented hoppers employed in different oceans. These skippers, along with fishers and fleet managers, described various hopper designs (e.g., mobile or integrated, with or without ramps) and how they are used in their daily fishing operations (**Figure 13**). Skippers who use hoppers with doors to control the flow to the lower deck are accustomed to using this tool and find it useful for quickly releasing bycatch from the upper deck. Most of them also did not experience delays in fish loading operations. Another skipper pointed out the benefits of clear visualization of the tuna caught in the hopper's tray, as well as minimizing the entry of unwanted catches (e.g., sharks and non-target bony fishes) into the wells.

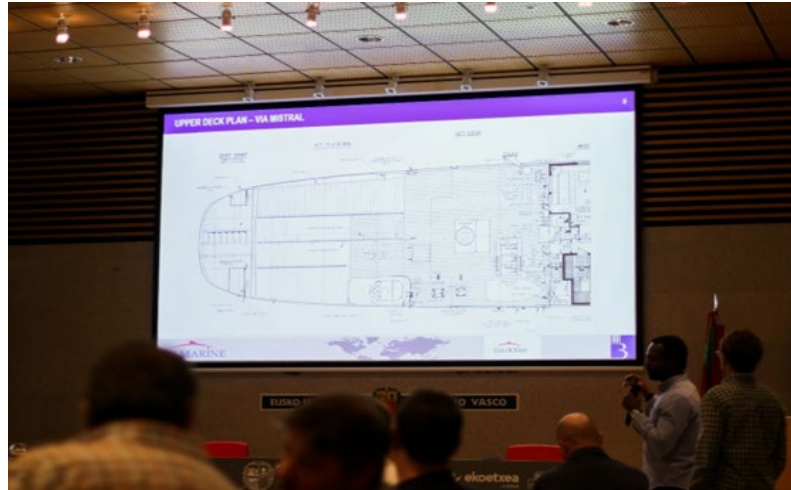

Figure 13 - Fleet manager presenting vessel deck configuration and use of hopper with ramp.

Hopper requirements

The choice of hopper (and ramp) for each purse seiner depends on the vessel's mode of fishing operation and the available deck space. The hopper can be situated to the starboard of the unloading hatch, directly on top of it, or to the portside (**Figure 14**).

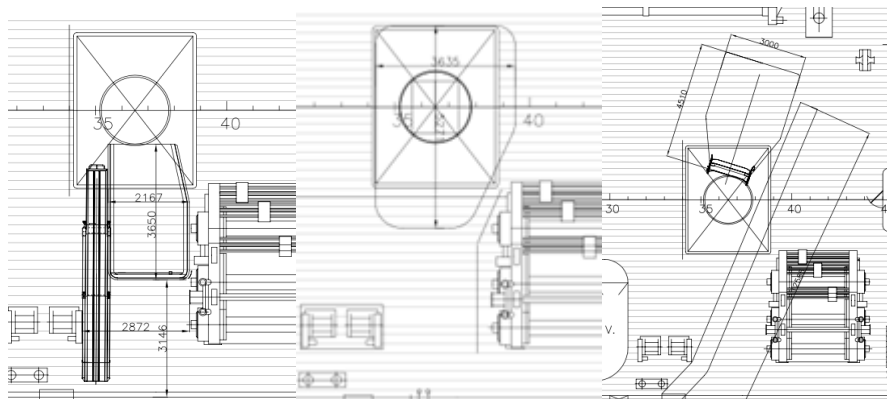

Figure 14 - Different hopper locations on deck: (Left) starboard, (Centre) centered over the unloading hatch, and (Right) portside.

Technologists also discussed that hoppers come in various forms and sizes, but two conditions are required for effective bycatch release: (1) the hopper's receptor tray must be large enough to spread out the catch for easy identification of bycatch species, and (2) there should be a stoppage system, such as a regulated door, to allow for the extraction of

bycatch species from the tray. Hoppers that do not meet these conditions act as mere "funnels," causing the brail contents to empty too quickly and hindering efficient release from the top deck.

Hopper operation

Fishers using hoppers emphasized the importance of controlled unloading of the brail contents, even in larger hoppers, to prevent overflow and spillage. Scientists presented release data from purse seiners operating in the Pacific Ocean, showing the efficacy of hoppers. For example, when the hopper was employed, only 4% of accidentally caught sharks ended up in the lower deck, compared to 66% when the hopper was not used (Murua et al., 2021b). Additionally, the use of a ramp from the hopper's side to the water's edge was found to be very useful for fast and safe bycatch release. Preliminary data from a recent research campaign in the Eastern Pacific Ocean, using hoppers with ramps and satellite tags on sharks, showed promising results with substantial increases in post-release survival rates (**Figure 15**).

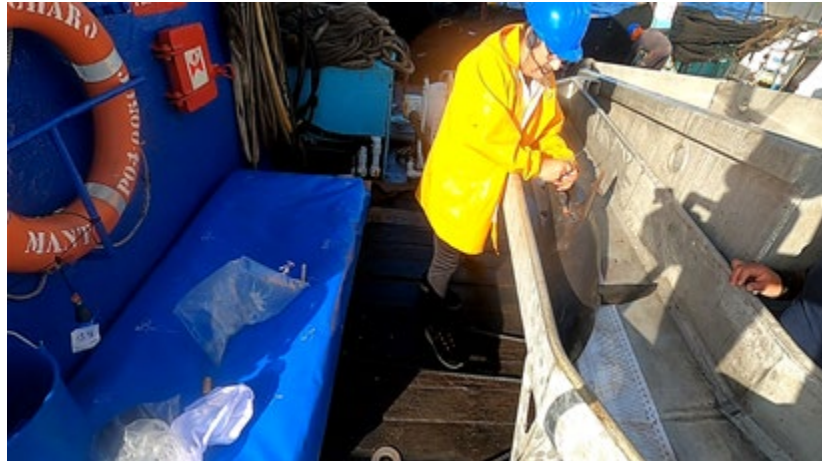

Figure 15 - Scientist putting a satellite tag on a silky shark (*Carcharhinus falciformis*) before release from a hopper with ramp for post-release survival study on board the Charo (Garavilla, Bolton Group) in the Pacific Ocean.

Hopper installation considerations

Following the presentations, a collaborative exercise was conducted in which mixed groups of fishers with and without hoppers on their vessels, scientists, and engineers discussed the limitations and potential solutions for installing hoppers in vessels that did not have them or improving those that already had one (**Figure 16**). The participants were also asked to estimate the associated costs (e.g., low, medium, high) to evaluate the feasibility of such modifications for ship owners or other stakeholders interested in implementing them in their fleets.



Figure 16 - Fishers and scientists engaging in discussions about the inclusion of BRDs on different vessels, using a small-scale working deck purse seiner model with mobile fishing and BRD equipment.

The consensus among the groups was that, except for smaller purse seiners (e.g., < 500 GT) where free space is limited, it would generally be possible to install a hopper that matches the scale of the deck space in most other vessels. Technologists mentioned that the average cost of a hopper with a ramp in recent times ranged from \$15,000 to \$25,000 USD, depending on materials used (e.g., aluminium, stainless steel) and the size/complexity of the design. Fishers and fleet managers found this cost to be highly affordable for a purse seine company, particularly considering it is a one-time investment that can last for decades on board. In comparison, other vessel expenses such as fuel, crew salaries, repairs, or even FAD construction and echo-sounder buoy purchases far outweigh the costs of hoppers.

Regarding installation on board, a common limitation on many purse seiners is the location of the chokers (i.e., small winches used to assist in pulling the sack onboard), typically positioned on the starboard side of the working deck. Most vessels have two chokers, usually placed towards the starboard and towards the stern of the principal winch. The distance between the winch and the first choker determines the width of the hopper and additional ramp if positioned on the starboard side (**Figure 17**). However, it should be noted that this does not prevent the installation of a hopper, as in most cases it can be positioned on the port side where more space is usually available. In fact, the majority of vessels using hoppers (e.g., USA fleet) have the hopper on the port side of the deck. Although this requires moving the hopper into position for each set, skippers report that the operation only takes 1-2 minutes. There may be instances where vessels with a small deck and a large net will have a significant portion of the deck occupied by the net during the sacking operation, which can restrict the introduction of a hopper (**Figure 18**).



Figure 17 - The hopper and ramp canvas templates are positioned on the port side to examine their installation viability due to the limited space between the winch with a protection cage (far left) and the two chokers (to the right) on the starboard side of the working deck.



Figure 18 - A view showing the two chokers and net occupying a large proportion of the working deck during the formation of the sack.

Sometimes these chokers also obstruct the starboard wall door, where the hopper's ramp ends, thereby blocking access to the ramp. An easy solution to this problem is opening a door in another area of the starboard wall that is not obstructed by the chokers. This minor structural modification can be easily implemented without requiring permits such as Bureau Veritas certifications. Another approach to avoid issues with chokers is constructing ramps that go over them, as chokers are usually not very tall elements (e.g., 0.5-0.7 m high), allowing for a steeper ramp. However, if a choker needs to be moved, it will involve more structural work and would likely be done during a vessel's major stoppage, such as the biennial or triennial dock repairs vessels typically undergo. This modification may also require readjusting the position of the boom. The cost for such alterations would likely fall within the medium range.

Some skippers highlighted that the Spanish brailing system differs from the American brailing style, with the latter being more suitable for hopper operations as it prevents the purse seine net being hauled from taking a lot of space on the deck. This enables easier storage and positioning of hoppers if they are used on the port side. On the other hand, with the Spanish brailing method, a significant portion of the deck space is occupied by the actively pulled-up purse seine netting. However, this style of operation might be faster in forming the sac and brailing, which can also influence shark survival (see Itano et al., 2003). There are ways to attempt fitting the hopper on the port side, such as redirecting the pulling ropes of the chokers or working with only the choker that sits to the starboard. A skipper who utilizes a hopper on the port side also clarified that his hopper sometimes rests on top of the net when necessary, which is not necessarily problematic. In certain cases, another solution is to design the hopper with a size and shape (e.g., asymmetrical shape) that helps avoid interference with the net or ropes of the chokers (**Figure 19**).

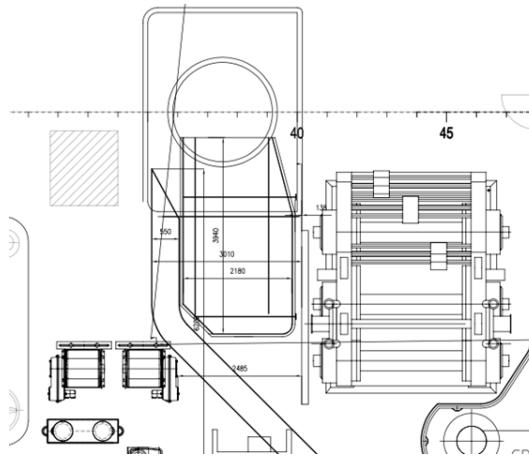

Figure 19 - A starboard hopper design with an asymmetrical shape and an L-shaped ramp to provide ample space for the two chokers to its left to operate.

An important element, according to fishers, when working with hoppers is to adjust the way the brail is operated to empty it. The capacity of the hopper, in terms of tons of fish it can hold, should always be smaller than that of the brail. As a general guideline, a hopper with a capacity to hold 75% of the brail's capacity is usually sufficient (e.g., for an 8-ton brail, use a 5-ton hopper capacity). This proportion works because the brail's catch is not emptied all at once onto the hopper's tray. Instead, it is important to allow the brail contents to "flow" gradually into the hopper, rather than being abruptly dumped. This controlled manner prevents the catch from overflowing and spilling out of the hopper's sides (**Figure 20**). The brail's operational mode, such as the unloading speed, is often regulated by the captain or navigator using the controls in the console. By using a steady "tap-tapping" procedure with the brail, where the fish contents are moved out in a controlled manner, overspilling can be avoided, and the crew has time to spot any bycatch species appearing in the tray and release them.

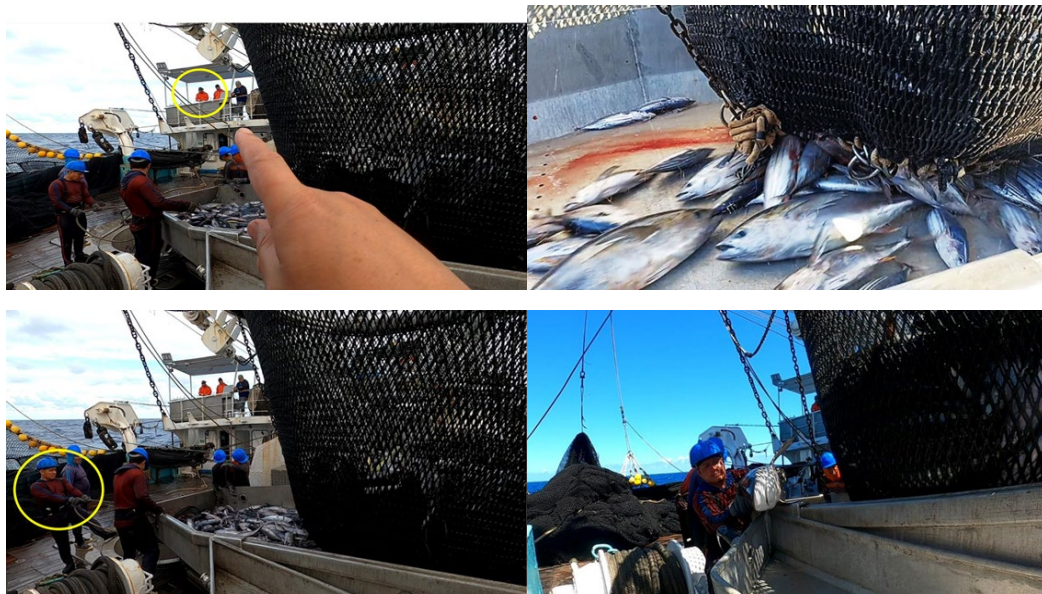

Figure 20 - Illustration of the correct brailing operation with a hopper: captain controlling brail flow from the console (top left), fish being unloaded gradually into the hopper by controlling the aperture of the bottom of the brail (top right), crew closing the door when bycatch is spotted (bottom left), and a shark being extracted from the hopper to be deposited on the release ramp (bottom right).

Fishers without hoppers questioned whether regulating brailing with a hopper would slow down the process of filling up the wells with the catch compared to directly emptying the brail into the unloading hatch. According to experienced skippers who use hoppers, there is no significant delay in fish unloading, even in the largest sets (e.g., > 100 tons) when unloading time is a concern due to the risk of histamine build-up. A study examining the sets of four Garavilla vessels in 2020 showed that the brailing time in sets where hoppers were used and sets where they were not used were not significantly different. Skippers argued that the unloading process is not slow; it is a controlled "flow" of fish going into the lower deck. It was also observed that all vessels, regardless of having a hopper or not, have a "trap door" in the lower deck between the unloading hatch and the conveyor belt to slow down fish movement when the brail is unloaded too quickly. This trap door is specifically designed to prevent fish from overspilling when they reach the lower deck conveyor belt. A person in the lower deck, usually the chief engineer, regulates the stoppage door with a control switch (**Figure 21**). This indicates that, to some degree, even in vessels without hoppers, brailing and the flow of fish into the wells must be somewhat controlled; otherwise, the conveyor belt cannot handle such a large volume of fish and it overflows, spilling out over the sides. In the case of hoppers, the flow is regulated from the upper deck, and without hoppers, it is regulated from the lower deck trap door.

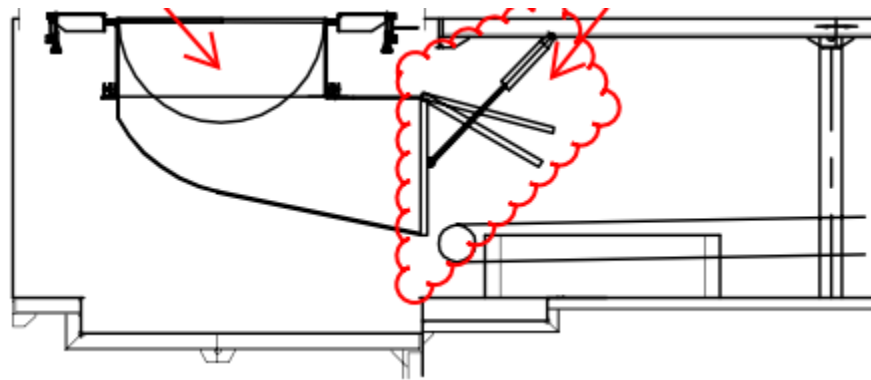

Figure 21 - Diagram of the lower deck showing the unloading hatch (left arrow) and stoppage door (right arrow) to regulate fish flow, located before the conveyor belt.

It is also worth noting that if bycatch release practices are being applied on vessels without hoppers, time will be lost when the brail is rested on the side of the deck, and the crew has to extract vulnerable bycatch species (**Figure 22**). Presumably, the bycatch releasing operation would be faster to implement in a hopper, as the animals are spread out and more accessible compared to trying to extract sharks and other species that are often trapped between a large mass of fish inside the brail. Most of these tests have been done in the Pacific Ocean, where the number of sets per day is lower than in other oceanic regions. Therefore, conducting trials in other oceans with different fishing strategies could help resolve doubts about the effect of hoppers on brailing time.



Figure 22 - Brail rested on the side of the top deck to take out bycatch in a vessel without a hopper.

Another aspect of hoppers that was discussed is which door stoppage mechanism is more efficient or easy to operate. In mobile hoppers, the door located at the lower end can be operated either manually (i.e., a crew member pulls a handle to lock the door in place) or with hydraulic systems connected to an outside control (**Figure 23**). Most fishers in the USA fleet have hoppers with hydraulic doors, which, in their view, are easier to operate, require less effort, and are safer for crew members.



Figure 23 - Mobile hopper door stop mechanisms: manual (left) and hydraulic (right).

For integrated hoppers (often used by the French fleet), participants were not aware of any stoppage door mechanisms being employed, which reduces their efficiency in preventing bycatch from reaching the lower deck (Maufroy et al., 2020). Naval engineers suggested having a similar hydraulic "trap door" mechanism as the one described before in the lower deck, but this time the door would be positioned higher up, closer to the working deck (i.e., at the unloading hatch level) (**Figure 24**). This would enable fishers to have access to move the bycatch out.

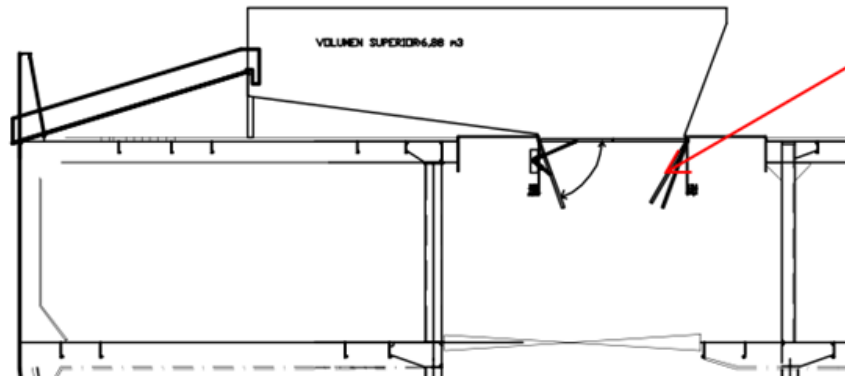

Figure 24 - Diagram of an integrated hopper with a ramp and hydraulic door mechanism (red arrow) at the base of the hopper at the unloading hatch level.

One of the more curious hopper designs, presented by a Croatian skipper working in the Western Pacific, features two doors—one located in the central part of the hopper where it narrows down, and another stoppage door at the base where it enters the unloading hatch (**Figure 25**). In vessels with this specific hopper system, the brailing time could be slowed down, making this design less suitable when fast brailing is needed.



Figure 25 - Hopper with a double stop door system in the middle and at the base (red arrows).

Another consideration when thinking of introducing a hopper is where it can be stored when not in use or in case of an emergency that requires clear deck space (e.g., a broken net that needs repairing). While integrated hoppers (centered over the unloading hatch) and mobile hoppers located on the starboard side are usually not moved until the vessel goes to port, portside hoppers will be stored away in some part of the deck (often near the winch) and repositioned only during the brailing operation. For each vessel, the storage position for the hopper will change depending on the available space among the rest of the fishing equipment on the deck. Alternatives exist to park the hopper on decks with limited space, such as positioning the hopper rolled on its side instead of flat to occupy less space, or even having "beds" or specially constructed frames on the winch to rest the hopper (**Figure 26**).

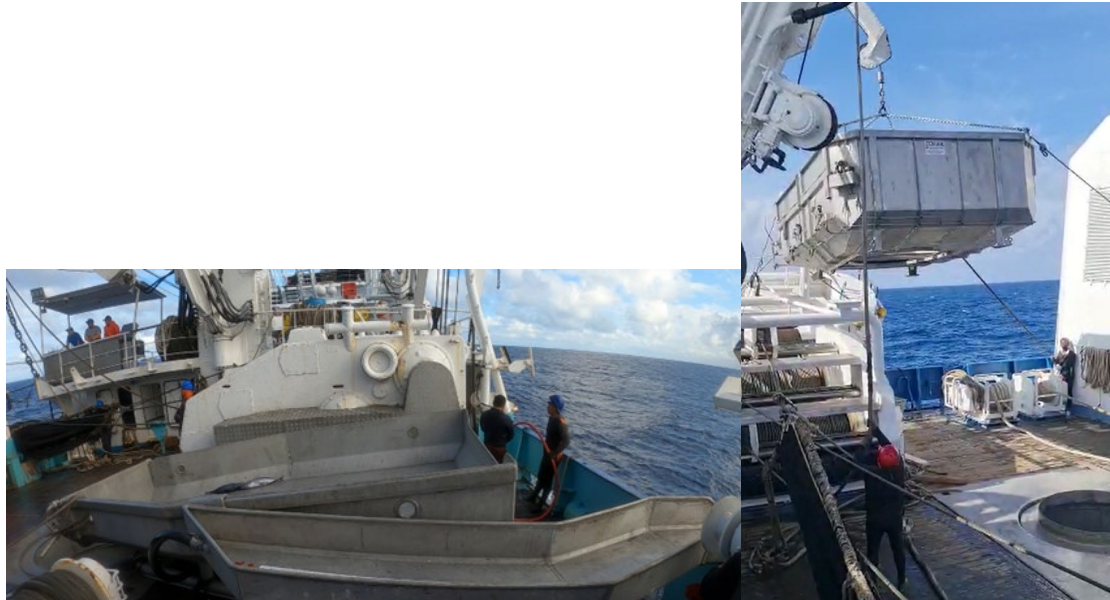

Figure 26 - Hopper with a ramp on the starboard side staying in the same position for the duration of the trip (left), and hopper being lifted to rest on a specially constructed "bed" on top of the winch (right).

Ramps for hoppers

The ramps going from the hopper to the wall opening to the water will vary in length, height, and degree of inclination depending on the hopper's position. For hoppers located on the portside, ramps can be quite long (e.g., 6-9 m), and thus enough initial height must be provided so that it has a degree of inclination that enables sharks and other bycatch to slide down unassisted, without the need to push the animals. However, the ramp should not be so elevated that fishers have to lift heavy sharks much higher than their waist level. Ramps with an initial flat section or "table" that can be manually lifted to gain more inclination if necessary have been successfully tried (**Figure 27**). Some of these ramps also have adjustable legs (e.g., using telescopic legs with holes and securing pins) to regulate the best height. For ramps that start at a low height, such as in integrated hoppers that are usually closer to the floor level (e.g., under 1 m high), mechanisms that enable tilting up the ramp to gain more inclination, either using simple options (e.g., elastic springs) or more complex ones (e.g., hydraulic or pneumatic systems), may work. The use of water hoses to wet the surface also enables animals to slide better.

These longer ramps usually consist of several sections (e.g., 2-3 sections of 3 m each). To reduce weight and space occupation when not in use, it is advisable to make them of aluminium and have sections that can be fitted inside another one when stored. Using telescopic ramps with sections that can be shortened after use can also help to take up less space. In some instances, the ramp will even end up in a section that can be lifted to allow easy crew passage if they need to access the other side of the deck, to prevent it from becoming a blocking element on deck (**Figure 27**).



Figure 27 - Ramp with lifting end section for easy crossing (left) and an elevatable "table" section and adjustable legs to select the best height for bycatch release (right).

As more hoppers with ramps are constructed in the future, new improved designs will emerge that can continue to increase the practicality of these BRDs. We encourage providers of fishing gear technology (e.g., shipyards, fishing gear companies) with considerable know-how and specialised construction facilities to get involved in the process of designing hoppers and ramps to make progress towards more efficient designs.

3.3. BYCATCH MITIGATION BEFORE SETTING AND SACKING

The primary focus of the workshop was on handling and releasing BRD best practices. However, other bycatch mitigation actions that could occur before the brailing operation were also discussed. From an impact mitigation standpoint, there is a hierarchical approach, with avoiding fishing gear interaction with bycatch species being the preferred option, followed by bycatch release options during the set, and after, release from the vessel.

Scientists first presented some of the work done in other fisheries to avoid spatio-temporal interaction with ETP species. These options included fishing zone exclusions, which could be either fixed (e.g., total closures, marine protected areas) or mobile (e.g., dynamic ocean models, moving rules, bycatch fleet alert programs). Fishers were also shown studies conducted in recent years in purse seine fisheries to mitigate shark bycatches through modifications in fishing operations and gear selectivity. Many of these initiatives have been conducted and sponsored by ISSF in their Bycatch Project-associated research cruises (see Restrepo et al., 2018). In those trials, alternatives such as attracting sharks away from the FADs with bait before the set or catching sharks away from the FAD were explored but not further tested due to the loss of time in the fishing operation and only partial interest from the sharks. In other experiments, shark "escape windows" were built in the net, but sharks did not readily pass through them (**Figure 28**). A scientist in the workshop questioned if a "secondary net" could be incorporated into the purse seine net to encircle the bycatch and move it towards the exit window or over the corks. Perhaps one of the most successful trials was fishing sharks with a handline in the net and releasing them outside. This operation was tested in two different research cruises, and on average, 20-30% of sharks in the net could be released in this way with almost 100% post-release survival. However, fishers showed low support for this protocol as it entails additional work for them during net hauling, a time during the fishing operation when all crew members are already fully engaged in other tasks.

Regarding conducting operations in the net to help release sharks and other bycatch once the purse is closed before brailing, fishers were somewhat reluctant. Some of their concerns include the loss of tunas caught escaping through windows/grids in the net or the extra crew needed to fish sharks in the net with handlines. The possibility of having a specially designated crew member to carry out or coordinate bycatch release actions (e.g., fishing sharks from the speedboat) should be considered in the future. Scientists pointed out that most bycatch mitigation actions will entail some kind of extra task required from crew members and that fishers should try to be proactive at this stage when ETP

regulations are still relatively mild. Lack of involvement or inaction by the industry in reducing bycatch of critically vulnerable species like sharks or mobulids at this stage might result in stricter and more drastic regulatory actions later.

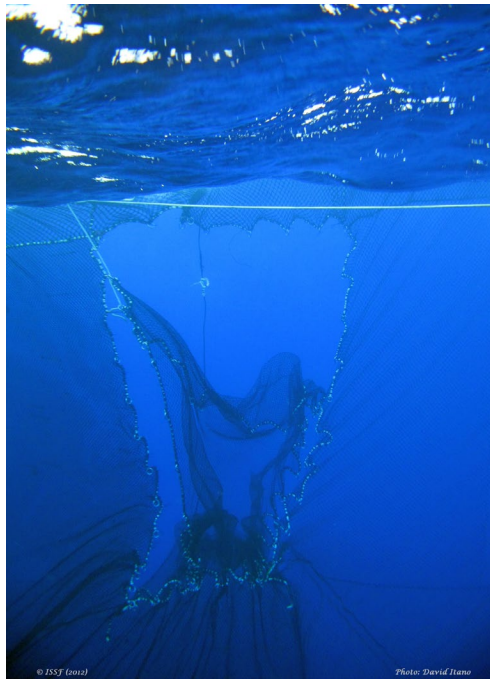

Figure 28 - Opening of a shark escape window during a set (© ISSF/Itano).

In general, fishers at the workshop expressed their preference for technical mitigation options rather than fishing area exclusions, as the latter can limit their access to fishing zones and potentially reduce their target catches. Identifying inefficient spatiotemporal windows for fishing could help minimize the influence on the target catch and gain acceptance from the industry (Ortuño-Crespo et al., 2022). It is worth remembering that tunas are highly migratory species, and their distribution and catchability can vary drastically depending on oceanographic conditions (e.g., El Niño - La Niña years). Therefore, permanent bycatch-related exclusion zones can have variable impacts on target tuna catches depending on the season or year. When considering technical solutions, fishers would prefer if sharks were somehow discouraged from swimming near the fishing area before the set, for example, through remote activation of light/sound by the FAD's buoy, bait attractors, or deterrents before sets, etc. However, a skipper commented that keeping sharks at FADs might be good for maintaining tunas aggregated under them and pointed out that it is not uncommon to find free school tunas behaving as "floating object schools" when sharks, whale sharks, or mobulid rays are present. While this kind of technology remains a potential possibility, there are still critical knowledge gaps regarding the differential sensory capabilities of pelagic sharks and target tunas. For example, it is still poorly understood what visual and auditory wavelengths pelagic sharks are able to detect and over which distance ranges they work. It should be noted that because a purse seiner net has a diameter of over 600 meters when it surrounds a FAD, deterrent stimuli need to effectively work over more than half a kilometer to prevent encircling sharks.

Regardless of the nature of the mitigatory stimuli employed (e.g., olfactory, visual, auditory, electromagnetic fields), it is important that these stimuli affect the bycatch species but not alter the behaviour of the target species (i.e., not scare tunas away from FADs). Ideas suggested by fishers in the workshop included trying different types of bait to attract sharks away from FADs for longer distances or to move them towards and out of escape windows, as perhaps there is some kind of taste or odor that elicits a stronger response than others. Another idea was to generate stimuli in the FAD that would scare away sharks, such as emitting noises of natural predators (e.g., killer whales) or even using visual images in

the form of holograms. In any case, everyone agreed on the importance of encouraging fundamental shark physiology and behaviour studies to better understand sensory capacities and identify stimulus-based strategies that can be exploited for bycatch mitigation. Given the high aggregative behaviour around FADs of sharks throughout their juvenile life stages (Filmlalter et al., 2015), more research should be directed towards gaining knowledge to develop attractors or repellents to keep sharks out of the fishing operation. On the other hand, remote bycatch detection and discrimination devices could help in decision-making before the set (e.g., buoys detecting shark presence at FADs). However, at present, the technology does not provide the fine resolution and species-specific discrimination for elasmobranchs.

Finally, in this part of the workshop, the design of purse seine nets was discussed in relation to reducing the time bycatch spends in the sac. It is widely acknowledged that mortality of tunas and accessory species rapidly increases once they reach the sac area of the net and species become more densely aggregated (**Figure 29**). Increased stress, crushing forces, and suffocation are among the problems that reduce the survival of animals in the sac. The duration of the sacking up and brailing operation of fish will depend on vessel characteristics such as the size of the brail, power of the winches, size of the net, the style of brailing, and importantly, the design of the net. It was hypothesized that reducing the sacking time of an average purse seiner, for example, from 25 minutes to 12 minutes, would not only increase the quality of the tuna brought onboard but potentially improve bycatch survival through reduced exposure to stressful conditions.

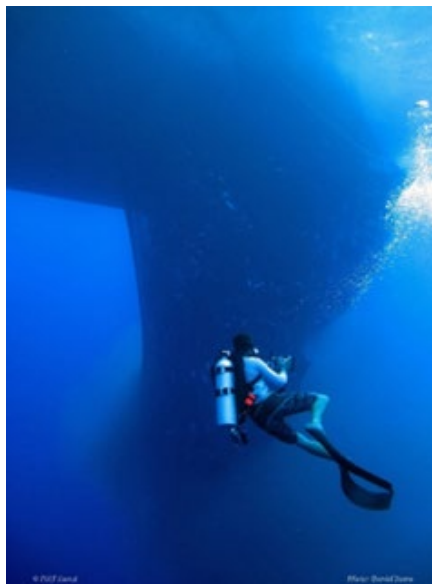

Figure 29 - Underwater view of catch aggregated in the sac (©ISSF).

Net builders with experience in several fisheries (e.g., anchoveta purse seine nets, demersal and pelagic trawlers, etc.) were invited to the workshop to discuss ideas with skippers to improve current tuna purse seine net designs. Although skippers are knowledgeable about some practical aspects of the use of their nets to efficiently encircle and catch tunas, it might also be fair to say that many are not experts in some of the more technical aspects of the net (e.g., different net material strengths, weights and configurations, net designs, etc.). The net builders at the meeting presented some options for improving the sacking time and efficiency of the net (e.g., reducing unnecessary net sections and weight that could lead to faster net hauling). Net builders, scientists, and fishers agreed that a dedicated meeting to explore tuna purse seine net design improvements should be organized in the near future. The objective would be to produce a modified net design blueprint with greater technical detail (i.e., using net-making software to calculate net panel length and configuration and estimate critical aspects such as net sinking rates, strength, etc.) that can improve the sacking time and efficiency of the net and evaluate the pros and cons to help ship-owners decide if they should implement it. Note that tuna

purse seine nets are not only very expensive, with some exceeding 1,000,000 USD, but also fishers' most important equipment to ensure the catch. Therefore, companies will need a high degree of certainty to trust such net design alterations will work before they consider embarking on such transformations.

3.4. TUNA PURSE SEINERS OF THE FUTURE

During the workshop, discussions took place regarding the limitations of installing BRDs in current tuna purse seiners. To envision more sustainable purse seiners for the future, an exercise was conducted (**Figure 30**), considering sustainability in terms of reducing impacts not only on ETP species but also on the entire marine environment.

One of the initial conclusions reached was that BRDs should be integrated into the vessel design phase right from the start. By doing so, the mitigation equipment for bycatch release can be more efficiently incorporated into the fishing operation as a whole. Current large-scale purse seiners have ample space on the top deck to accommodate larger BRDs, such as hoppers with ramps. However, the installation of BRDs onboard is sometimes compromised due to the positioning of minor elements like chokers and davits, which occupy strategic spaces on the upper deck. By considering the fishing and BRD equipment during the design phase of the working deck in relation to the entire fishing operation, their incorporation can be facilitated to ensure a more space-efficient deck and comfortable release operations. Vessels of the future should be constructed not only to maximize fishing efficiency for target species but also to maximize the live return of bycatch species back to the sea.

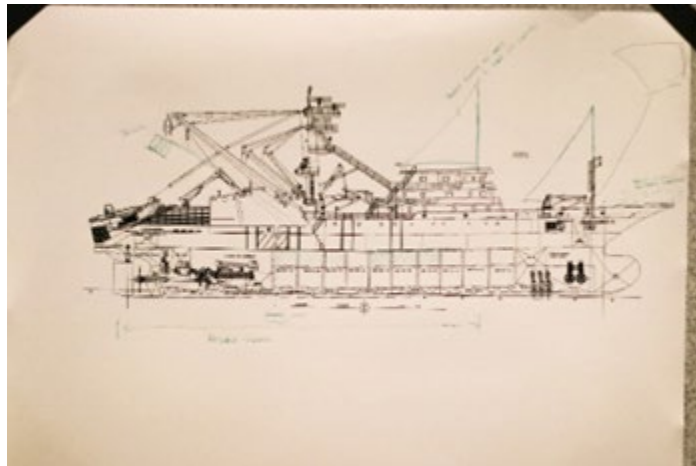

Figure 30 - Scientists and skippers discussing future purse seine vessel designs (top), and vessel diagram with annotations on the use of triplex and wind-powered movement (bottom).

Several participants discussed futuristic alternatives for integrating BRDs, such as release equipment that could be stored below the deck's surface and emerge when needed using hydraulic systems. This would provide a clear working deck when BRDs are not in use. Others suggested the use of large hoses and vacuum systems to pump the catch alive onto

the working deck, with the assistance of artificial intelligence for sorting the target catch by species (e.g., skipjack, bigeye, and yellowfin), and quickly returning the bycatch to the sea. While these concepts may seem somewhat unrealistic and futuristic, some of these technologies have already been in use for years in technologically advanced fleets such as the Norwegian small pelagic and salmon aquaculture sectors. For example, modern aquaculture well boats in Norway and Chile employ large hoses connected to vacuum pumps to transfer live salmon at a rate of more than 400 tons per hour between cages, with almost 100% survival rate and sorting by sizes (**Figure 31**).



Figure 31 - Vacuum pump hoses and classification systems on the deck of well-boats for live transport of salmon in Norway.

Some participants also mentioned the use of triplex systems to haul the net in a faster and safer manner, eliminating the need for a power block and a skiff. It was noted that some vessels, such as those in Japan, already utilize triplex systems (**Figure 32**). The adoption of such technological changes in tuna purse seine fisheries has been slow because even older operating vessels can still achieve relatively good catches. Therefore, ship-owners are often hesitant to introduce novel technology onboard, as it requires not only a significant initial economic investment but also a trial-and-error phase for proper adjustments, which may result in lost fishing opportunities and lower short-term returns.



Figure 32 - Triplex net hauling system in a modern tuna purse seiner at the port of Yaizu (Japan).

In addition to advancements in purse seine technology, associated fishing technologies of the future, such as selective echo-sounder buoys capable of accurately discriminating and quantifying different species, including bycatch, could help

reduce trips to FADs with high bycatch proportions. Other tools could incorporate artificial intelligence to make decisions on whether to set on certain FADs or assess onboard safety risks and prevent them.

As more fisheries are regulated by systems such as catch quotas per vessel (e.g., Peruvian anchoveta purse seine fishery), companies need to increase their efficiency (e.g., lower fuel costs, reduced travel time) and the market price of their products (e.g., higher-quality fish preservation systems, eco-certified products) to maximize economic benefits. Some workshop participants believed that the use of brine-preserved wells for fish destined for canning products would be replaced by ultra-freezing tunnels (e.g., -45 °C) for higher-end products like sashimi in better-paying markets.

3.5. ACTIONS TO PROMOTE BRD IMPLEMENTATION

To summarize the workshop discussions, an open discussion was conducted to identify the three principal actions that fishers, scientists, and ship-owners in this fishery should undertake to support the implementation of BRDs (**Figure 33**). Additionally, participants were asked to classify the degree of difficulty in implementing these actions: easy (E), moderate (M), or difficult (D). They were also asked to determine the time period in which such actions could be applied: short-term (ST), medium-term (MT), or long-term (LT). The comments from participants on these actions are also included.

a) Fishers:

Action 1: Fishers should be open to trying new BRDs on their vessels, especially if these have been previously tested and proven to be safe and efficient. They should also inform scientists of the results of their implementation (Difficulty: E; Time: ST).

Comments: Participants suggested that fishers should be willing to test prototypes of BRDs during commercial fishing trips, particularly in the initial stages of development. They emphasized the importance of providing feedback to scientists and technologists on the performance of BRDs to improve their efficiency and safety. Improved communication channels, such as online social media platforms (e.g., WhatsApp) and in-person meetings, should be utilized to facilitate information sharing between fishers and scientists. This action was considered easy to implement and could be done in a relatively short period.

Action 2: Skippers should proactively ask ship-owners to provide them with the necessary BRDs (Difficulty: E; Time: ST).

Comments: By expressing their interest in using BRDs to ship-owners, skippers send a clear message about their commitment to sustainability. Ship-owners are more likely to invest in BRDs if fishers actively request them. On the other hand, if fishers show reluctance, it may discourage ship-owners from adopting these tools. Requesting BRDs was deemed an easy action that could be accomplished in the short term.

Action 3: Fishers could establish working groups within their companies to develop better tools and protocols (Difficulty: M; Time: ST).

Comments: Participants suggested that fishing companies can independently develop BRDs and best practices without solely relying on scientists and technologists. Fishing companies interested in advancing BRD technology can collaborate with fishers to design, construct, and test new mitigation solutions. Establishing working groups within companies (e.g., fleet managers, fleet inspectors, fishers) may pose some challenges in terms of coordination, especially if skippers are frequently at sea. However, it can be set up relatively quickly and was seen as moderately difficult.



Figure 33 - Group of fishers, scientists and naval engineers discussing bycatch mitigation options.

b) Ship-owners:

Action 1: Ship-owners should facilitate the interaction between their fishers and scientists/technologists to develop and test BRDs and other impact mitigation actions (Difficulty: E; Time: ST).

Comments: Ship-owners play a crucial role in approving collaborations between fishers and scientists. Encouraging such collaborations demonstrates transparency and proactive commitment to sustainable practices. Ship-owners were advised to be more receptive to scientists' recommendations, even if they involve additional costs or efforts. This action was considered simple to implement and could be done in the short term.

Action 2: Ship-owners should implement a BRD use policy in their vessels and allocate capital for constructing or purchasing the required BRDs to ensure best practices are followed (Difficulty: E; Time: MT).

Comments: Ship-owners' willingness to invest in selective equipment may vary. Industry-wide agreements, such as Codes of Best Practices, could incentivize non-proactive ship-owners to adopt BRDs. Some fleet managers argued that the costs associated with BRDs are relatively small compared to other expenses, and the investment can be recouped through improved fish sales. Ship-owners with canneries may be more likely to invest in BRDs and other environmentally friendly initiatives to meet market demands for sustainable products. Participants considered this action easy to adopt, and the implementation period could be short to medium term, depending on the number of vessels requiring BRDs.

Action 3: Ship-owners (and managers) should consider skippers' opinions when making decisions on sustainable fishing and directly communicate such information to crew members (Difficulty: E; Time: ST).

Comments: Fishers expressed frustration that their opinions are often disregarded in decision-making processes related to sustainability. Ship-owners and managers should actively involve skippers in discussions and take their perspectives into account. Skippers believed that ship-owners or scientists should directly communicate with the crew regarding sustainable practices, as they are already occupied with their daily fishing tasks. This action was considered easy to apply and could be done in the short term.

c) Scientists:

Action 1: Scientists should conduct studies with BRDs and analyse the data to establish their efficiency in increasing bycatch survival (Difficulty: E; Time: ST).

Comments: Scientists are responsible for conducting experiments and performing robust statistical analyses to determine the efficacy of different BRDs. The results obtained can provide evidence of the benefits of employing BRDs and quantify the mitigation gains associated with their implementation. This action was considered easy to carry out and can be applied in the short term.

Action 2: Scientists should disseminate BRD study results in Regional Fishery Management Organizations (RFMOs) and other forums to raise awareness among managers, NGOs, and the general public (Difficulty: E; Time: ST).

Comments: Fishers expressed the need for greater recognition of their sustainability efforts. Scientists were urged to make more significant efforts to highlight positive results, not only in scientific journals but also in wider-reaching media. Scientists acknowledged the challenges they face in terms of time constraints but suggested seeking assistance from publicity agencies to improve dissemination through newsletters and social media. This action was considered easily executable in the short term.

Action 3: Scientists should be more receptive to fishers' opinions to expedite the improvement of BRDs and should also meet with ship-owners to address issues and necessary actions (Difficulty: E-M; Time: ST).

Comments: Fishers felt that their opinions are often overlooked in scientific work, resulting in slower progress in developing effective mitigation solutions. Skippers emphasized the importance of scientists engaging more frequently with ship-owners to accelerate the adoption of marine conservation practices. Scientists should advocate for change by organizing dedicated workshops with ship-owners. The degree of difficulty may vary, depending on ship-owners' interest and availability. These meetings could be organized in the short term.

d) Managers:

Action 1: Managers should adopt realistic and stepwise sustainability implementation procedures (Difficulty: M; Time: MT).

Comments: Participants believed that a gradual implementation approach is necessary to encourage ship-owners and fishers to adopt effective BRDs on board. This stepwise implementation allows companies to experiment, learn, and adapt BRDs to their specific requirements vessel by vessel. The implementation period should provide enough time for companies to adopt BRDs without rushing the process, yet not be so long that it significantly delays acting, risking irreversible population declines for ETP species.

Action 2: Managers should consider fishers' opinions when planning sustainable fishing measures (Difficulty: E; Time: ST).

Comments: This action aligns with the need for stakeholders above fishers in the hierarchical ladder to take their concerns and opinions into account. Fishers' up-to-date knowledge of fishing strategies and experience can contribute to the formulation of more efficient conservation measures. Considering fishers' inputs increases the likelihood of their willingness to comply with mitigation measures. This action could be easily implemented in a relatively short period of time.

Action 3: Managers should consider more seriously the positive and negative results from bycatch mitigation research projects (Difficulty: E; Time: ST).

Comments: Significant advancements have been made in the last five years through research campaigns to reduce bycatch mortality and increase crew safety. Managers should consider the results of these studies when implementing effective actions, especially if proven to work. However, managers should also be aware of research indicating challenges in implementing certain mitigation actions under real fishing conditions to avoid passing measures that are difficult to implement or have limited efficacy. It was believed this action could be easy and fast to implement.

Participants expressed it would be important to pursue some of these actions in the future to promote working connections between the different stakeholders that can amend the current state of bycatch impacts in the fishery.

4. FINAL CONCLUSIONS and RECOMMENDATIONS

A final open discussion took place to reach an agreement among participants regarding the immediate activities that should be prioritized to improve the designs and adoption of BRDs for handling and release practices, as well as other impact reduction actions on a broader scale. The following key recommendations were agreed upon:

- Fishers and fishing companies that currently do not have BRDs onboard should seriously consider trying them, as these tools are highly adaptable to many types of vessels. As more fishing vessels join environmentally friendly programs such as MSC eco-certification, vessels that fall behind in best bycatch mitigation practices will be seen as unsustainable. Some companies in the Spanish fleet, for example, have committed to equipping all of their vessels with mobulid sorting grids and release ramps. Importantly, testimonies from other fishers who regularly use these BRDs have convinced them about their viability and advantages. In the meeting, fleet managers and skippers from companies that did not have hoppers with ramps in any of their vessels expressed their intention to implement these tools soon (before the end of 2023). One conclusion from the workshop was that most BRDs can be customized and scaled to fit the requirements of different purse seiner types, from small to large scale. Vessels that face difficulties in implementing these tools due to deck space constraints should consider minor modifications (e.g., opening doors on the side of the deck's wall for ramps to evacuate bycatch; see **Figure 34**) or larger structural modifications (e.g., relocation of fishing equipment such as chokers).



Figure 34 - Proposed door opening (red square) to install a straight release ramp, as the two chokers obstruct the passage to the door already in place.

- Studies to improve and develop new BRDs should be further promoted. As more vessels try out BRDs, there will be an evolution in designs towards more efficient, safe, and practical release equipment. To accelerate progress towards better handling and release tools and protocols, research should continue to be supported by scientists, fishing gear manufacturers, and the industry. Studies on new technologies should be conducted to identify potential solutions for bycatch avoidance. These could include working on different sound and light wavelength emitting apparatuses, such as integrating them into echo-sounder buoys, to selectively deter elasmobranchs from FADs. Fishers also highlighted the need for further research on new technologies like manipulation suckers in the form of suction cups or blankets, which can help handle and move large and dangerous bycatch species in a safer manner.

- Permanent joint technical committees consisting of fishers, scientists, and technologists should be formed to develop environmental impact mitigation solutions at both regional and international levels. Involving skippers and crew in sustainability research and solution-generation processes, such as the design and trials of selective BRDs and bycatch reduction protocols, will foster positive perspectives and proactive attitudes among fishers. Fishers and scientists from the Basque region, where the workshop was held, agreed that they would be willing to set up a collaborative committee to improve sustainable practices, and it should be formed soon. It was also noted that fishers' participation in these consultative bodies would require the initial approval of ship-owners. These consultation committees could be organized at the national fleet level, but the idea of having a multinational panel consisting of well-respected skippers and scientists from different Regional Fisheries Management Organizations (RFMOs), coordinated and funded by an international agency such as ISSF or FAO, could also be worth considering.



Figure 35 - RFMO meeting between managers and the scientific advisory committee, without fishers, to advise them on conservation measures.

- Updating the best bycatch handling and release practice guidelines, which have been revised by fishers, was another agreed recommendation. Participants acknowledged that the current recommended guidelines for bycatch release should be upgraded to incorporate the latest advances in BRDs over the last decade. Scientists proposed the development of new guidelines, but it was agreed that before publishing them, they should be reviewed by skippers and crew. This collaborative approach aims to create a better fit-for-purpose guide, using terminology that is more suited for fishers and emphasizing points that they consider important. The result should provide a set of best practices for bycatch safe handling and release that fishers perceive as their own, encouraging voluntary adoption.

This workshop highlights the importance of bringing together key tuna purse seine fishery actors from multiple fleets worldwide to identify necessary actions and approaches to advance BRD development and promote sustainable fisheries.

ACKNOWLEDGEMENTS

We would like to express our gratitude to the participating skippers and fleet managers for their time and collaboration. We also acknowledge their respective ship-owners and companies for coordinating their attendance, including Albacora, Atunsa, Cape Fisheries, Caroline Fisheries Corporation, Echebatar, Garavilla Bolton Group, Inpesca, Nirsa, Ugavi, and Via Ocean Bolton Group. Special thanks are due to Astilleros Murueta, Eurored, and TH/Marco for their assistance in technical vessel and fishing equipment specifications. We also extend our thanks to DMC Studio for their excellent work with the vessel's deck and BRDs model. This workshop was sponsored by ISSF, with additional funds from the EU Next Generation project HOP-NEXT for the construction of bycatch release tools displayed at the workshop. We also would like to acknowledge funding by the Global Environmental Facility (GEF) provided through the Common Oceans Tuna Project, implemented by FAO, which is a unique and innovative partnership working towards transformational change in tuna fisheries management and biodiversity in areas beyond national jurisdiction.

REFERENCES

- Davies, R.W.D., Cripps, J., Nickson, A. and Porter, G. 2009. Defining and estimating global marine fisheries bycatch. *Marine Policy* 33, 4, 661-672. <https://doi.org/10.1016/j.marpol.2009.01.003>.
- Escalle, Lauriane, E., Murua, H., Amande, J., Arregui, I., Chavance, P., Delgado de Molina, A., Gaertner, D., Fraile, I., Filmlalter, J., Santiago, J., Forget, F., Arrizabalaga, H., Dagorn, L., and Meringot, B. 2016. Post-capture survival of whale sharks encircled in tuna purse-seine nets: tagging and safe release methods. *Aquatic Conservation: Marine and Freshwater Ecosystems*, 26, 4, 1052-761. <https://doi.org/10.1002/aqc.2662>
- Filmlalter, J.D., Cowley, P., Forget, F., and Dagorn, L. 2015. Fine-scale 3-dimensional movement behaviour of silky sharks *Carcharhinus falciformis* associated with fish aggregating devices (FADs). *Mar. Ecol. Ser.* 539, 207-223.
- Gilman, E., Chaloupka, M., Booth, H., Hall, M., Murua, H., and Wilson, J. 2023. Bycatch neutral fisheries through a sequential mitigation hierarchy. *Mar. Pol.* 150, 105522. <https://doi.org/10.1016/j.marpol.2023.105522>.
- Gilman, E., Perez, A., Huntington, T., Kennelly, S. Suuronen, J. P., Chaloupka, M. et al. 2020. Benchmarking global fisheries discards. *Nature Scientific Reports* 10, 1,14017. DOI: 10.1038/s41598-020-71021-x
- Hall, M.; Roman, a., 2013. Bycatch and non-tuna catch in the tropical tuna purse seine fisheries of the world. *FAO Fisheries and Aquaculture Technical Paper No.* 568.
- Hutchinson, M. R.; Itano, D. G.; Muir, J. A.; Holland, K. N., 2015. Post-release survival of juvenile silky sharks captured in a tropical tuna purse seine fishery. *Mar. Ecol.-Prog. Ser.*, 521, 143-154.
- Jenkins, L.D. 2010. Profile and influence of the successful fisher-inventor of marine conservation technology. *Conservation and Society* 8 (1): 44-54.
- Maufroy A, Gamon, A., Vernet, A-L., and Goujon, M. 2020. 8 Years of best practices onboard French and associated flags tropical tuna purse seiners: an overview in the Atlantic and Indian Ocean. IOTC-2020-WPEB16-11.
- Murua, J., Ferarios, J.M., Grande, M., et al (2021a) Developing solutions to increase survival rates of vulnerable bycatch species in tuna purse seine FAD fisheries. In: IOTC - 2nd ad hoc Working Group on FADs. IOTC-2021-WGFAD02-11_rev1, Online
- Murua, J., Grande, M., Onandia, M., and Santiago, J. 2021b. Improving on deck best handling and release practices for sharks in tuna purse seiners using hopper with ramp devices. Seventeenth Regular Session of the Scientific Committee, WCPFC, SC17-EB-IP-13.
- Onandia, I., Grande, M., Galaz, J.M., Uranga, J., Lezama-Ochoa, N., Murua, J., Ruiz, J., Arregui, I., Murua, H., Santiago, J. 2021. New assessment on accidentally captured silky shark post-release survival in the Indian Ocean tuna purse seine fishery. IOTC-2021-WPEB17-13.
- Ortuño-Crespo G, Griffiths S, Murua H, et al. 2022. Reducing shark bycatch in tuna fisheries: adaptive spatio-temporal management options for the eastern Pacific Ocean. In: IATTC - 11th Meeting of the Working Group on Bycatch. IATTC BYC-11-04, Online, p 31
- Poisson, F., Vernet, A. L., Séret B., Dagorn L., 2012. Good practices to reduce the mortality of sharks and rays caught incidentally by the tropical tuna purse seiners. EU FP7 project #210496 MADE, Deliverable 6.2, 30p.
- Poisson, F.; Filmlalter, J. D.; Vernet, A.-L.; Dagorn, L., 2014. Mortality rate of silky sharks (*Carcharhinus falciformis*) caught in the tropical tuna purse seine fishery in the Indian Ocean. *Canadian Journal of Fisheries and Aquatic Sciences*, 71 (6), 795-798.
- Sandoval, J., Jadhav, S., Quan, H., Deheyn, D., Tolley, M. 2019. Reversible adhesion to rough surfaces both in and out of the water, inspired by clingfish suction discs. *Bioinspir. Biomim.* 14 066016.

ANNEX I – LIST OF PARTICIPANTS

ISSF Bycatch Reduction Device Workshop Participant List (Torre Madariaga, Busturia, Spain).

NAME	PROFESSION	VESSEL	COMPANY
Josu Marcos	Skipper	Rosita C	Garavilla (Bolton Group)
Urko Labajos	Skipper	Ugavi	Ugavi
Pascal Provost	Skipper	Via Avenir	Via Ocean (Bolton Group)
Albert Soares	Skipper	Cape Breton	Cape Fisheries
Marin Dunatov	Skipper	Melissa	Caroline Fisheries Company
Josu Bilbao	Skipper	Albatun III	Albacora
Iñaki Zugadi	Skipper	Txori Gorri	Inpesca
Mikel Monasterio	Fleet Manager		NIRSA
Miguel Angel Fernandez	Fleet Manager		ATUNSA
Joseba Blanco	Fleet Inspector		Garavilla (Bolton Group)
Olivier Nonga	Fleet Inspector		Via Ocean (Bolton Group)
Kepa Laka	Fleet Inspector		Echebaster
Josu Apraiz	Naval Engineer		Murueta Shipyard
Igor Almagia	Naval Engineer		TH/MARCO
Diego Blanco	Net builder		Eurored
Javier Blanco	Net builder		Eurored
Gala Moreno	Scientist		ISSF
Hilario Murua	Scientist		ISSF
Jose Maria Ferarios	Fishery technologist		AZTI
Maitane Grande	Scientist		AZTI
Jefferson Murua	Scientist		AZTI



**ISSF BRD workshop participants at Torre Madariaga
(Busturia, Basque Country)**

ANNEX II – AGENDA

ISSF WORKSHOP ON DECK BYCATCH REDUCTION DEVICES (BRDs) FOR VULNERABLE SPECIES IN TROPICAL TUNA PURSE SEINERS

20-21 April 2023, Torre Madariaga, Busturia (Basque Country)

DAY 1

- 9:00-9:30 - Opening of the workshop and description of objectives.
- 9:30-10:30 - Presentation of BRDs: hoppers of the world, requirements to release sharks and manta rays properly.
- 10:30-12:00 - Presentation by fishers on the characteristics of their vessels and maneuvers with BRDs.
- 12:00-12:30 – Coffee break
- 12:30-14:00 - Group exercise: Limitations in current purse seiners to install BRDs and how they can be solved, and calculation of associated costs.
- 14:00-15:00 – Lunch break
- 15:00-16:30 – Other devices (grids, ramps, velcro, etc.). Open discussion of user needs and possible improvements.
- 16:30-17:00 – Group exercise: Improving bycatch survival before brailing. Open discussion on how to minimize elasmobranch mortality before they arrive on deck (repellents to move away from FADs, modifications in the net, etc.)
- 20:30 - Group dinner

DAY 2

- 09:00 – 10:30 - Group exercise: Exercise on what tuna purse seiners of the future should be like with BDRs fully integrated.
- 10:30-11:00 - Group exercise: Table of actions that each stakeholder (scientists, fishers, ship-owners, managers) should conduct to promote the use of BRDs.
- 11:00-12:00 – Coffee break
- 12:00-13:30 - Group exercise: Proposals for guide on best BRD practices in purse seiners
- 13:30-14:00 – Conclusions



www.iss-foundation.org

3706 Butler Street, Suite 316
Pittsburgh, PA 15201
United States

Phone: + 1 703 226 8101
E-mail: info@iss-foundation.org

